

WELD PAK™ 2000

Spare Parts.....	1
Figure A, B, C: Machine Assembly	2
Figure D: Wire Drive and Euro Socket Assembly.....	4
Miscellaneous Items (not shown in figure A, B, C, D)	4
Electrical Schematic	5
WEEE	6



Spare Parts

SP50291 REV02
12/05

ASSEMBLY PAGE NAME			Machine Assembly	Machine Assembly	Wire Drive Assembly	Wire Drive and Euro Socket Assembly	Miscellaneous Items	
CODE NO.:	K NO.:	FIGURE NO.:	A	B	C	D	-	
50291	K14134-1	WELD PAK™2000	1	1	1	1	1	

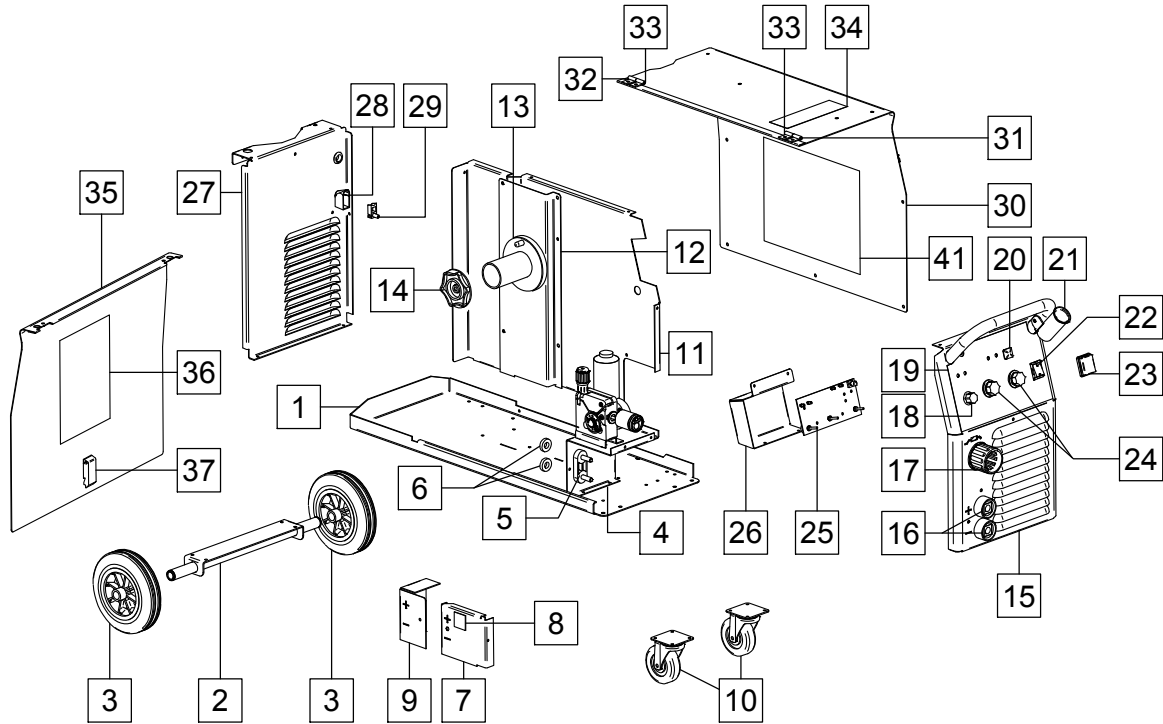

Figure A

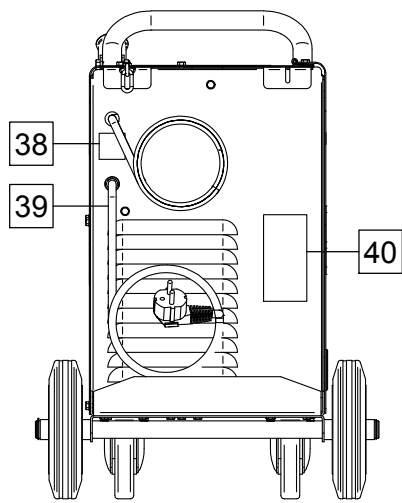

Figure B

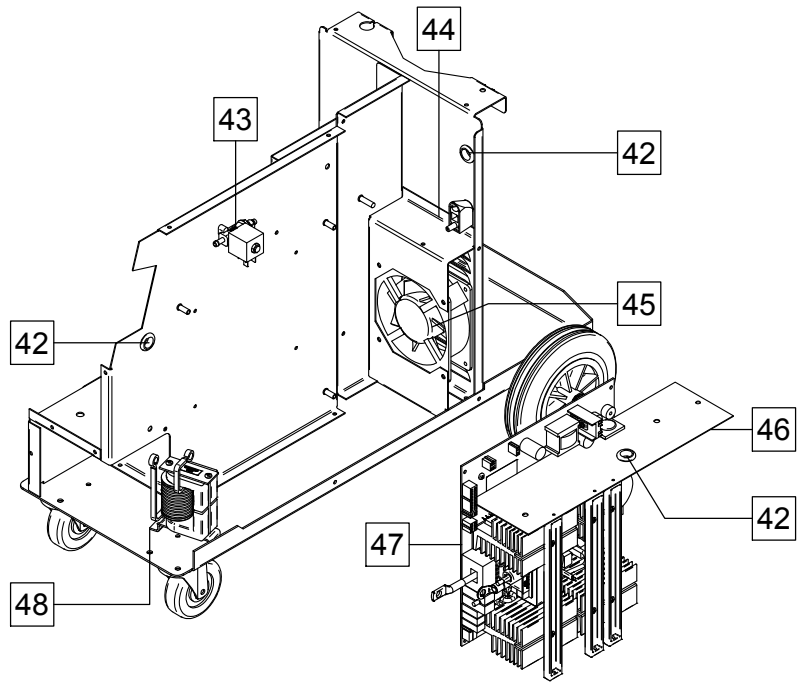

Figure C

Figure A, B, C: Machine Assembly

Item	Description	Part Number	QTY	1	2	3	4	5	6	7
1	BASE	R-1019-376-1/08R	1	X						
2	BRACKET	R-3019-337-1/08R	1	X						
3	REAR WHEELS	1029-660-007R	2	X						
4	BRACKET	R-3019-356-1/08R	1	X						
5	TERMINAL BLOCK	1361-599-328R	1	X						
6	INSULATOR RINGS	1361-599-670R	2	X						
7	COVER	R-3019-346-1/08R	1	X						
8	STICKER	2719-107-732R	1	X						
9	COVER	R-1019-380-1/08R	1	X						
10	FRONT WHEELS	1029-660-004R	2	X						
11	DIVIDER	R-3019-334-1/08R	1	X						
12	BRACKET	R-1019-377-1/08R	1	X						
13	REEL HUB STANDARD	0744-000-192R	1	X						
14	PLASIC NUT	B11035-1	1	X						
15	FRONT PANEL	R-3019-332-1/08R	1	X						
16	SOCKETS X2, X3	C-2986-001-2R	2	X						
17	EURO SLEEVE	1361-599-708R	1	X						
18	CONTROL	9ST13639-3	1	X						
19	STICKER (FRONT PANEL)	R-0010-535-1R	1	X						
20	RUBBER BUTTON	1373-182-005R	1	X						
21	GUN HOLDER	R-3019-211-1/08R	1	X						
22	SWITCH	1115-270-019R	1	X						
23	BLACK FRAME SHIELD	1115-299-073R	1	X						
24	CONTROLS	9SS18425-1	2	X						
25	P.C. BOARD	Y031-1R	1	X						
26	COVER	R-1019-381-1/08R	1	X						
27	REAR PANEL	R-1012-634-1/08R	1	X						
28	CABLE RELEIF	1361-599-399R	1	X						
29	CLAMP	1361-599-398R	1	X						
30	COVER	R-1019-412-1R	1	X						
31	HINGLE WITH AXLE	D-3574-011-4/02R	1	X						
32	HINGLE WITH AXLE	D-3574-011-3/02R	1	X						
33	HINGLES	D-3574-007-1/33R	2	X						
34	STICKER	2719-107-728R	1	X						
35	WIRE DRIVE DOOR	R-1019-411-1R	1	X						

36	STICKER (WELDING TABLE)	R-0010-544-1R	1	X						
37	LOCK	0654-610-004R	1	X						
38	STICKER (GAS)	2719-107-733R	1	X						
39	POWER LEAD (3M)	R-5041-331-1R	1	X						
40	STICKER (HEIGHT OF GAS CYLINDER)	R-7040-228-3R	1	X						
41	STICKER (WIRING DIAGRAM)	R-0010-541-1R	1	X						
42	RUBBER BUSH	1373-182-002R	3	X						
43	GAS SOLENOID	0972-423-040R	1	X						
44	FAN BAFFLE	R-1019-378-1/08R	1	X						
45	FAN	0873-100-034R	1	X						
46	DEFLECTOR	R-0010-458-2R	1	X						
47	P.C. BOARD	R-6042-069-1R	1	X						
48	CHOKE L1	R-4034-148-1R	1	X						

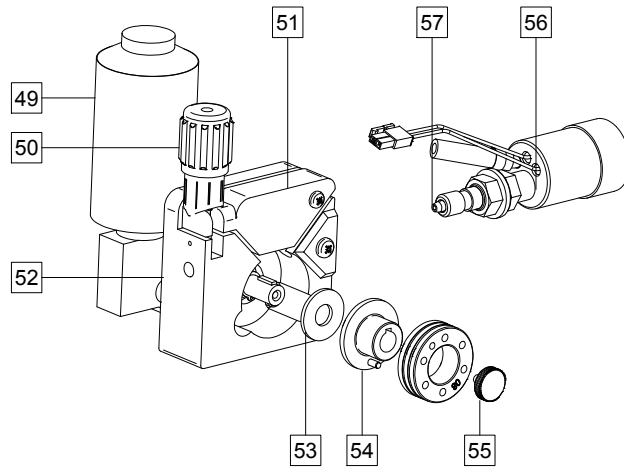

Figure D

Figure D: Wire Drive and Euro Socket Assembly

Item	Description	Part Number	QTY	1	2	3	4	5	6	7
	WIRE DRIVE ASSEMBLY	0744-000-269R	1	X						
49	MOTOR	0744-000-270R	1	X						
50	FIXING ARM COMPL.	0744-233-015R	1	X						
51	PRESSURE ARM COMPLETE	0744-000-249R	1	X						
52	FEED PLATE	0744-000-271R	1	X						
53	WASHER	0744-000-272R	1	X						
54	ADAPTER	0744-000-250R	1	X						
55	FIXING CAP	0744-000-251R	1	X						
56	EURO SOCKET X3	R-8040-362-1R	1	X						
57	OUTLET GUIDE	R-2010-006-4R	1	X						

Miscellaneous Items (not shown in figure A, B, C, D)

Item	Description	Part Number	QTY	1	2	3	4	5	6	7
58	HARNESS (PRIMARY)	R-5041-337-1R	1	X						
59	WIRES	R-5041-338-1R	2	X						
60	WIRE	R-5041-339-1R	1	X						
61	HARNESS (SECONDARY)	R-5041-341-1R	1	X						

Electrical Schematic

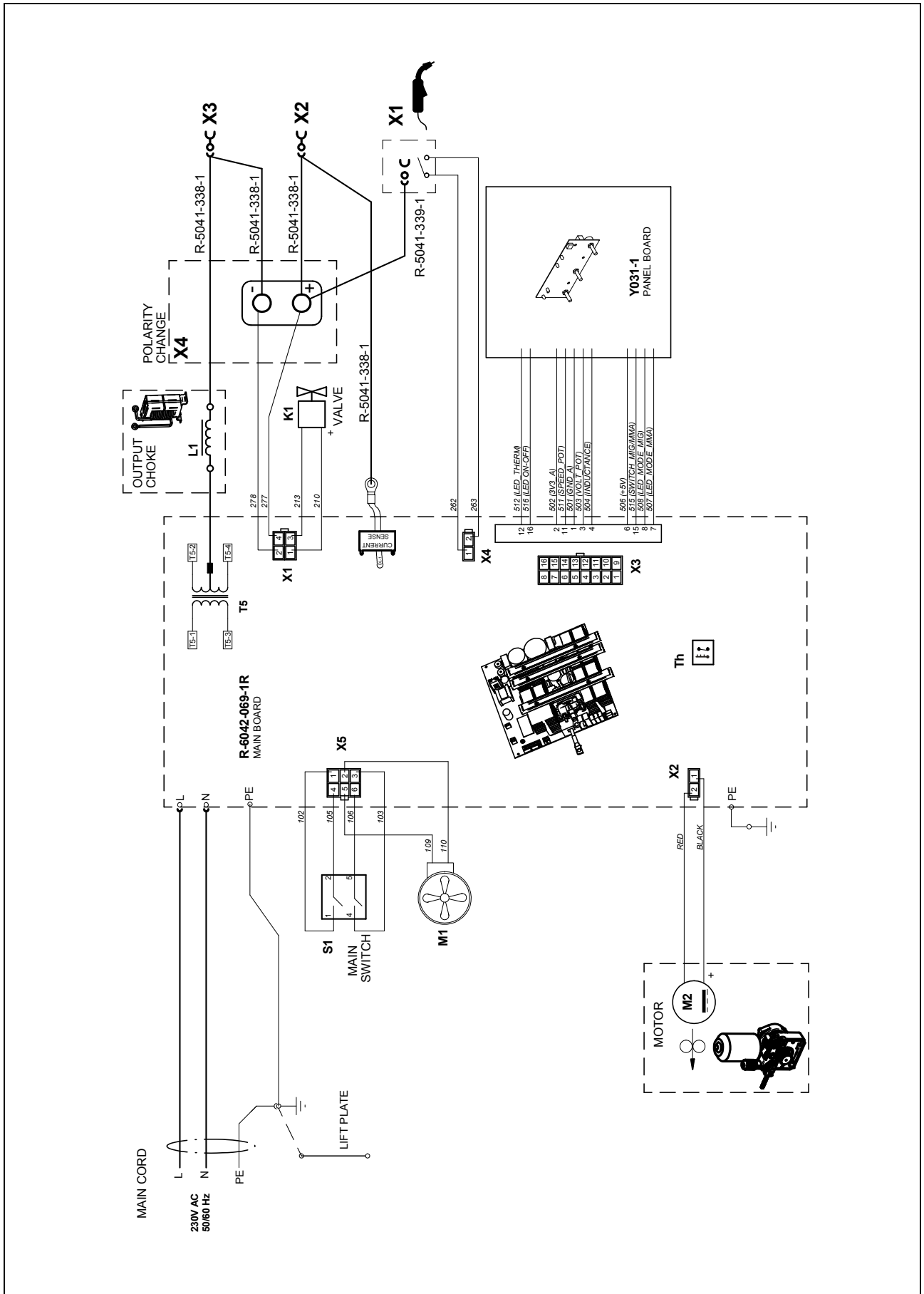

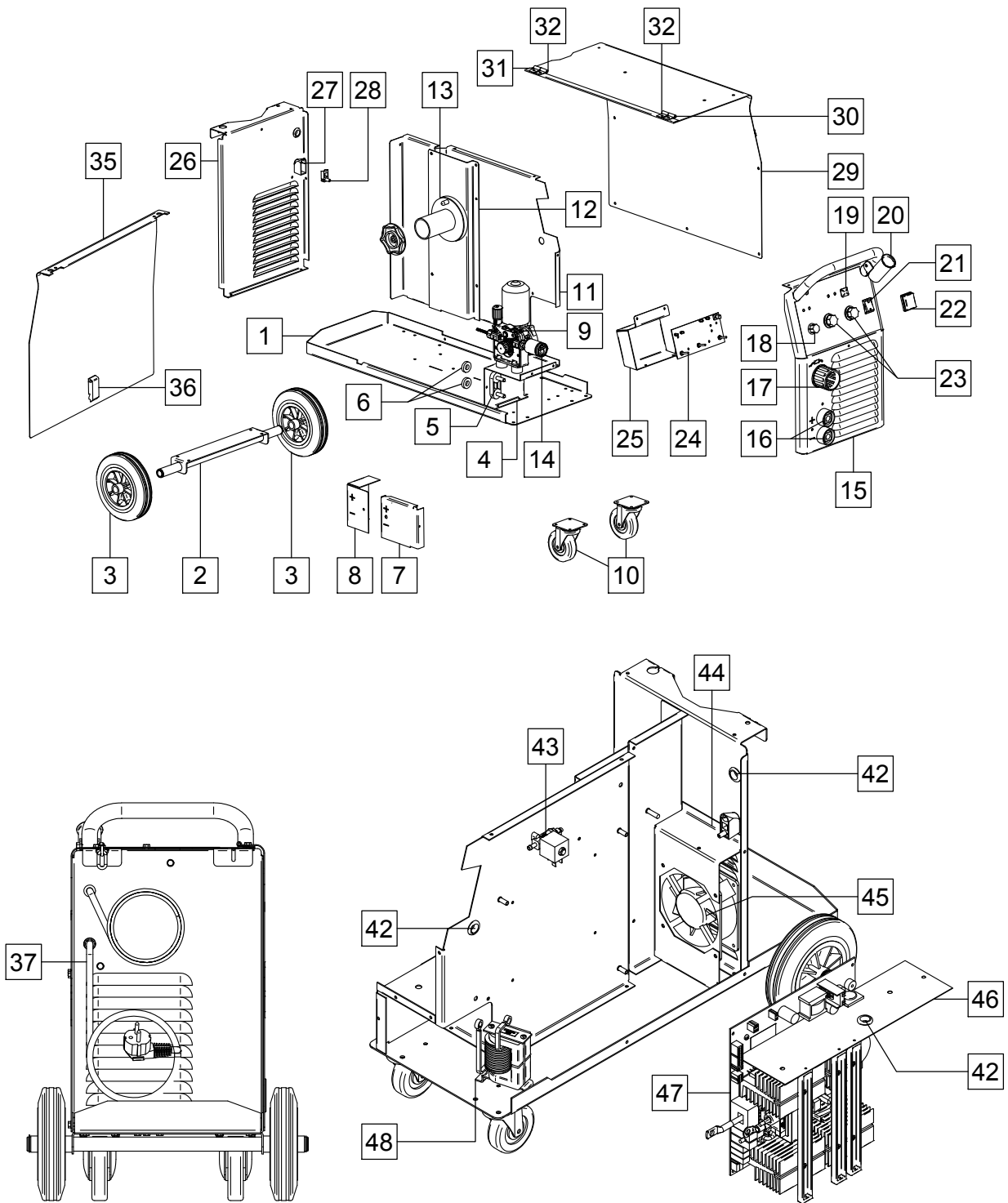

Description	Ref.	Recycle				ST				
		Fe	Al	Cu	Brass	Boards	Plastics	Liquid Cristal	External Electric Cables	Capacitors
BASE	1	X								
REAR PANEL	26	X								
FRONT PANEL	15	X								
BAFFLE	11, 12, 44									
COVER	7, 8, 25, 29	X								
LOCK	36						X			
WIRE DRIVE DOOR	35		X							
FAN	45			X			X			
HINGLE	30, 31, 32	X								
P.C. BOARDS	24, 47					X				
WIRE REEL SPINDLE	13	X					X			
BRACKET	2, 4	X								
EURO SOCKET	14				X		X			
EURO SLEEVE	17						X			
SOCKET	16	X		X			X			
BLACK FLAME SHIELD	22						X			
CONTROL	18, 23						X			
BUTTON	19						X			
GAS SOLENOID	43	X		X	X					
INSULATOR RING	6						X			
WIRE FEEDER	9	X		X			X			
TERMINAL BLOCK	5				X		X			
POWER LEAD	37			X	X		X			
REAR WHEEL	3						X			
FRONT WHEEL	10		X				X			
SWITCH	21				X		X			
LIFTING EYE	20	X								
RUBBER CABLE BUSH	42						X			
CABLE RELIEF	27, 28						X			
CHOKE	48	X		X			X			
DEFLECTOR	46						X			