

Quality Control Inspection Report

DESCRIPTION	C1022 S/D IHW Hd TypeB #2 reduced point "J2" Dia.14mm GAL. Bonded Cond. EPDM no painted Case Hardened Z/P 5um CR3			
SPECIFICATION	M4.8 -16x20/0	PART NO.	9999700801	INSPECTION STANDARD

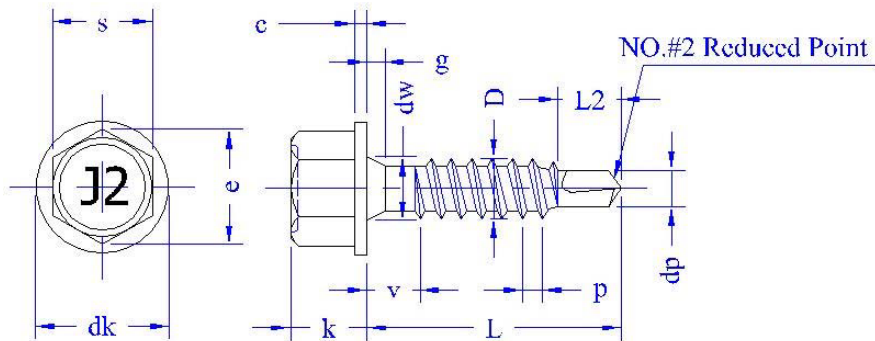

NO	INSPECTION ITEM	(PCS)	AQL	STANDARD VALUE	ACTUAL VALUE
1.	HEAD HEIGHT	20	4.00	4.8 – 5.10 mm	4.87 – 4.89 mm
2.	HEX (A/F)	20	4.00	7.70 – 7.85 MM	7.71 – 7.83 mm
3.	HEX (A/C)	20	4.00	8.47 Min. mm	8.80 – 8.87 mm
4.	WASHER DIAMETER	20	4.00	9.80 – 10.50 mm	10.06 – 10.25 mm
5.	WASHER THICKNESS	20	4.00	0.90 Min. mm	0.92 – 0.97 mm
6.	LENGTH OF UPPER CSK UNDER HEAD	20	4.00	1.30 – 1.50 mm	1.41 – 1.47 mm
7.	DIA. OF UPPER CSK UNDER HEAD	8	1.00	4.50 – 5.00 mm	4.93 – 4.96 mm
8.	UNTHREAD LENGHT	20	4.00	3.50 – 4.00 mm	3.80 – 3.90 mm
9.	THREAD MAJOR DIAMETER	20	4.00	4.80 -4.90 mm	4.86- 4.89 mm
10.	PITCH	8	1.00	1.60 Ref. mm	1.60 – 1.62 mm
11.	DRILL POINT DIAMETER	20	4.00	2.80 – 2.90 mm	2.84 -2.86 mm

Quality Control Inspection Report

DESCRIPTION	C1022 S/D IHW Hd TypeB #2 reduced point "J2" Dia.14mm GAL. Bonded Cond. EPDM no painted Case Hardened Z/P 5um CR3			
SPECIFICATION	M4.8 -16x20/0	PART NO.	9999700801	INSPECTION STANDARD

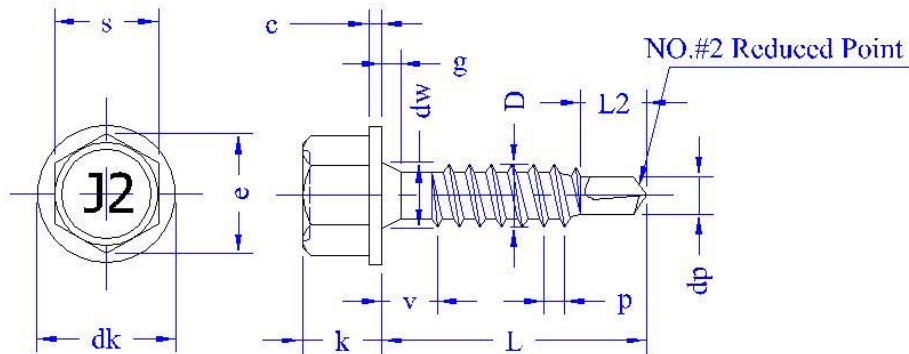

NO	INSPECTION ITEM	(PCS)	AQL	STANDARD VALUE	ACTUAL VALUE						
12.	FLUTE LENGTH	20	4.00	4.50 – 5.50 mm	5.25 – 5.44mm						
13.	TOTAL LENGHT	20	4.00	19.00 – 20.00 mm	19.52 – 19.73 mm						
14.	APPEARANCE	50	4.00	VISUAL	OK						
15.	SURFACE HARDNESS (HV 0.3)	6	1.00	HV 560 Min. ↑	HV 606 - 649						
16.	CORE HARDNESS	6	1.00	HRC 37 - 43	HRC 40.8 – 42.20						
17.	TORSIONAL STRENGTH	6	1.00	65 Min. ↑ kg/cm	94 - 103 kg/cm						
18.	PLATE THICKNESS	8	1.00	0.7 X 2 mm	0.7 X 2 mm						
19.	SAMPLING METHOD (ISO 3269)										
INSPECTION ITEM		STANDARD VALUE		1	2	3	4	5	6	7	8
DRILLING SPEED		3000 sec.max		1.37	1.42	1.44	1.27	1.50	2.11	1.39	1.83

Result Pass

All measuring values before surface treatment.

EJOT Romania

Șos. Comercială nr. 21 A, DN 65 B, Com. Bradu, Sat Geamăna, Jud. Argeș, RO-117141

phone: +40 248 2238 – 86 / fax: +40 248 2238 - 84

e-mail: infoRO@ejot.com / Internet: http://www.ejot.ro