

www.heco-topix-plus.com

HECO-Schrauben GmbH & Co. KG
Dr.-Kurt-Steim-Straße 28, 78713 Schramberg, Germany
Phone +49 (0)7422/989-0, Fax +49 (0)7422/989-200

57411 - 02/2020 Subject to change.



**HECO-TOPIX®-plus:
Makes the best
even better.**

HECO-TOPIX®-plus: The screw with a technological advantage.

HECO-TOPIX®-plus is a real screw highlight, combining concentrated technological expertise and wide range of tangible user benefits in a single wood screw. The secret: Our HECO-TOPIX®-plus combines the best properties of four HECO ranges!

With the innovative properties of the HECO-Drive, GripFit, MagicClose and PerfectPitch, a new, integrated drive size concept and high-quality system accessory, HECO-TOPIX®-plus is the perfect wood screw for practically all applications. You benefit not only from the impressive technological advantage, but also above all from simple handling and optimum performance.

GripFit

HECO-Drive for single-handed operation. Holds stainless steel screws securely on the bit too. T-Drive-compatible.



Countersunk head with milling pockets

Excellent milling features in wood, no damage to the surface with metal fittings.

MagicClose

Patented full thread pulls timber fixtures together without gaps and without pretension.



PerfectPitch

Thread pitch optimal for every screw length. Perfect performance for all wood applications.



HECO premium quality

Innovative high-quality solutions from the screw specialists from the Black Forest.

TOPIX® tip

Reduces the risk of splitting the wood and enables tighter edge and centre spacing.

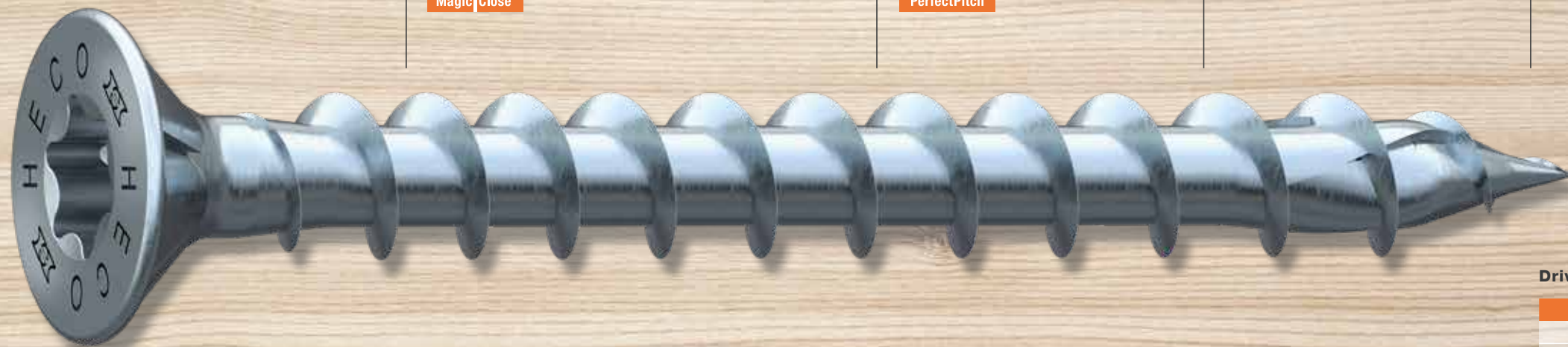

Drive size & bit colour concept

Ø	HD	PZD
3,0	HD-10	PZD-1
3,5	HD-20	PZD-2
4,0	HD-20	PZD-2
4,5	HD-20	PZD-2
5,0	HD-20	PZD-2
6,0	HD-30	PZD-3
8,0	HD-40	—
10,0	HD-40	—

In the Black Forest, the people are innovative and so are the screws.

What do you combine with a company from the Black Forest? Exactly: inventiveness, diligence and quality awareness. And these are precisely the qualities that have defined HECO since its foundation in 1888. The best proof of our innovative capabilities are the numerous patents that we hold.

The most recent example is MagicClose, the ingenious “contraction effect” that makes it possible to screw wooden components together without any gaps. And thanks to the most stringent load tests and quality checks, our products are as high-quality and durable as they are unique. Anything screwed together with HECO will stay securely in place for a very long time. We owe this to our typical Black Forest quality awareness.



MagicClose: Contraction effect without pretension.

As anyone trying to screw two timber fixtures together knows: To prevent a gap between the two components, you usually need to use part-threaded screws or to stress the components using a clamp. Not with HECO-TOPIX®-plus full-threaded screw Ø3.5–6.0. Thanks to the MagicClose innovation from HECO, both fixtures are pulled together and secured by the thread of the screw.

The screw is “quicker” at the front than at the back as a result of its decreasing thread pitch. This means that the two timber fixtures form a stable connection without any gaps, allowing for higher tensile loads compared to part-threaded screws. At the same time shorter screws can be used, which helps to save time and material costs.

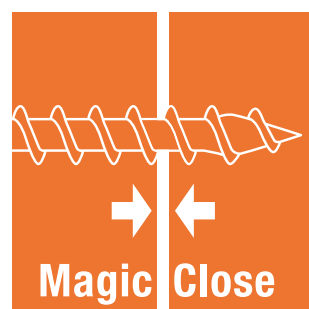

Screw thread pitch: higher at the front, lower at the back.
The effect: the screw is quicker at the front than at the back.
The fixture is drawn on to the substructure.

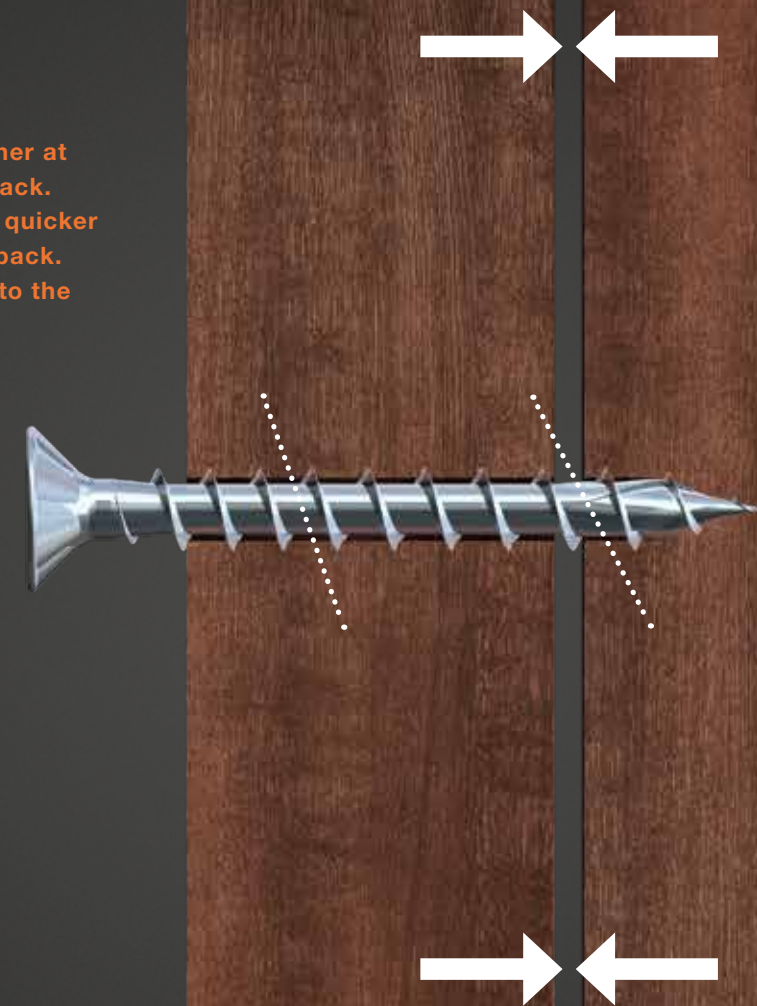

GripFit: Single-handed operations, now possible with stainless steel too.

At the construction site, every bit of help is welcome, and work is much easier when you have a free hand. So having magnetic bits that hold the screw on the tool are a huge help. And what's even better; this is now possible with stainless steel screws too. Thanks to the HECO-Drive with GripFit effect.

The perfectly coordinated system works mechanically, not magnetically: The bit has a slightly conical shape, which means that the screw is held onto the bit through friction – permitting you to carry out your work easily with one hand. With HECO-ClicFix, the bit is held securely in the machine and can be quickly replaced. HD bits and T-Drive bits are both compatible with HD screws and T-Drive screws.

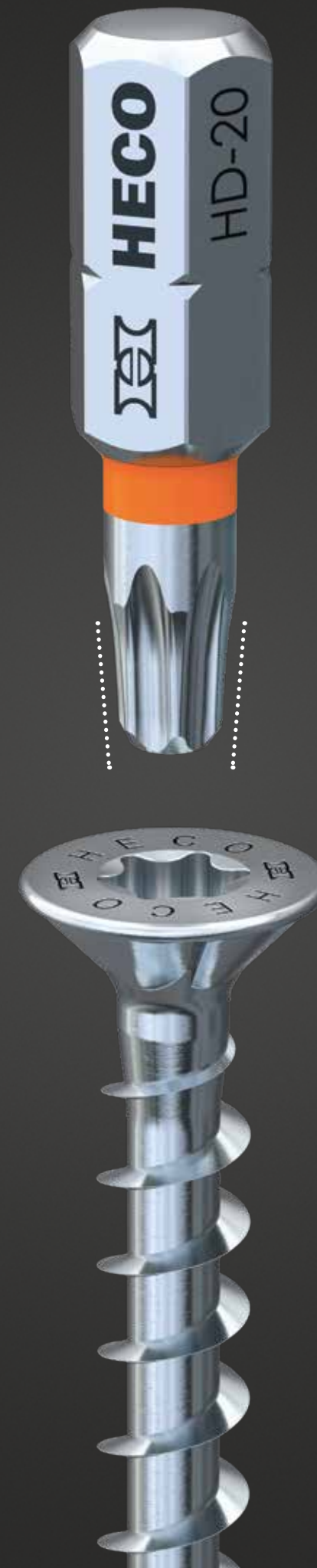
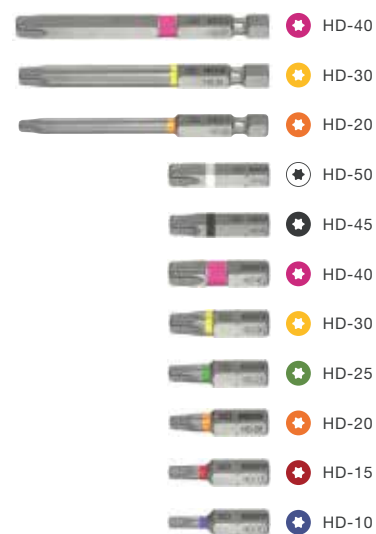
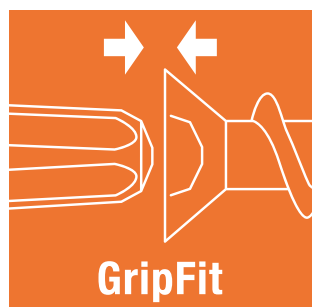

The geometry of the HD bit is conical. This mechanically “glues” the bit to the screw.

In order to ensure a perfect fit, the bits and the screws must be produced with extremely high levels of precision.

This does not only ensure optimal transmission of the power of the screwdriver, but it also wears the bit less.

PerfectPitch: Optimised thread pitch for every screw length.

The unique PerfectPitch technology ensures perfect performance in all wood applications: The thread pitch has been optimally adapted based on the particular screw length. A lower pitch prevents overtightening with short screws, and a high pitch means that long screws can be driven in quickly.

An additional benefit of the HECO-TOPIX®-plus thread: With part-threaded screws, the shank ribs above the thread expand the insertion hole. The resulting reduction of friction makes it much easier and quicker to insert the screw. The new TOPIX® tip reduces the driving torque additionally.



Short screws:
These require the smallest possible thread pitch in order to have more thread inside the wood and to anchor themselves ideally in the material.

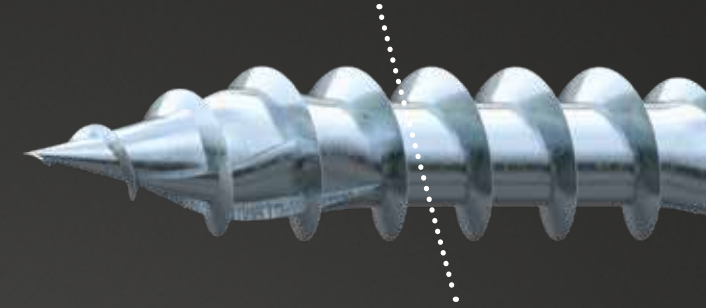

Medium-length screws:
These require a medium thread pitch in order to guarantee that a sufficient thread is screwed into the material after an acceptable insertion time.

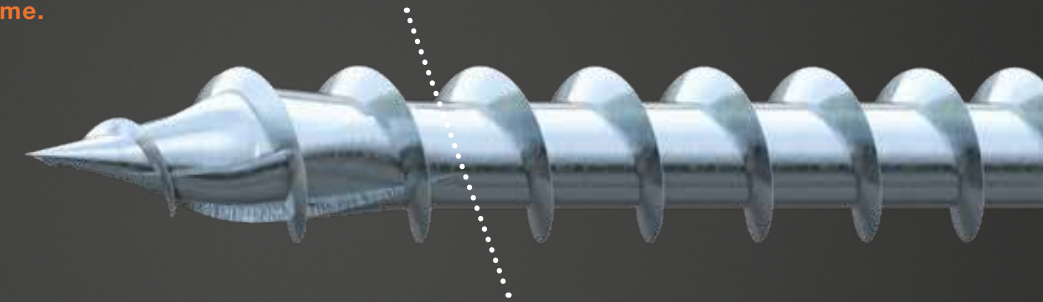

Long screws:
These require a high thread pitch so that they can be inserted in wood as fast as possible.

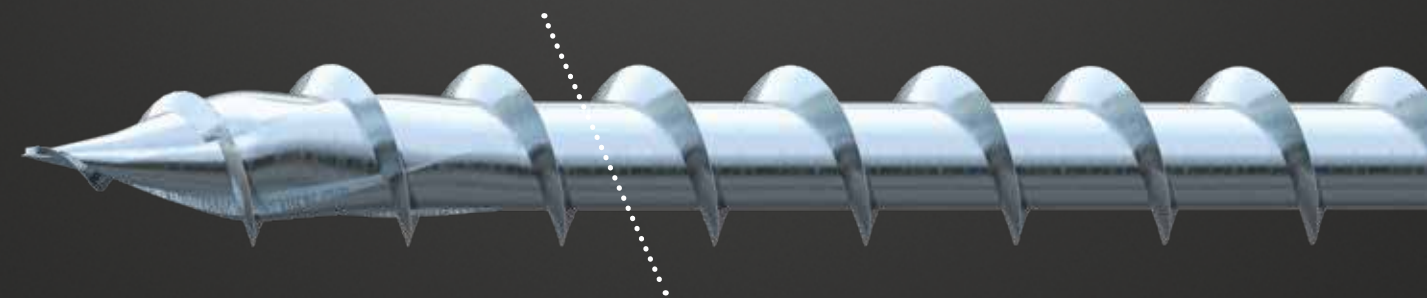

HECO-TOPIX®-plus: Nobody needs more screw.

Whatever job you need to do: The extensive and well conceived HECO-TOPIX®-plus range has the right screw for all applications.

PZ, HD or T drives, head geometries and thread variants for an extremely wide range of applications, with full or part thread as terrace, flooring, solar, thermal, glazing bead, rear panel or post screws, either blue or yellow galvanised or stainless steel. The galvanised versions in thicknesses 8µm are generally free of hexavalent chromium. In other words: HECO-TOPIX®-plus is as versatile as your daily work.

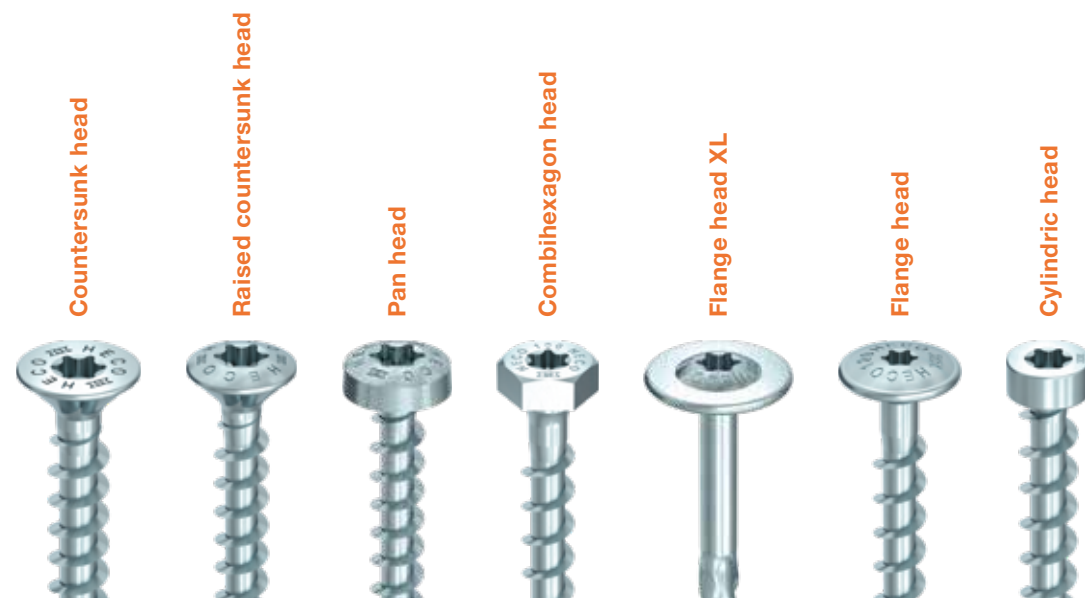

Range overview

	bright zinc plated yellow zinc plated stainless steel A2	Countersunk head with milling grooves full/part threaded PZD, lengths (mm): 10 to 200 diameters (mm): 2,5 / 3,0 / 3,5 / 4,0 / 4,5 / 5,0 / 6,0	
	bright zinc plated	Countersunk head with center drilled hole full threaded PZD, lengths (mm): 20 to 80 diameters (mm): 4,0 / 4,5 / 5,0	
	bright zinc plated	Reduced countersunk head full threaded PZD, lengths (mm): 12 to 35 diameter (mm): 3,0	
	bright zinc plated stainless steel A2	Pan head full threaded PZD, lengths (mm): 10 to 80 diameter (mm): 2,5 / 3,0 / 3,5 / 4,0 / 4,5 / 5,0 / 6,0 T-Drive, lengths (mm): 12 to 80 diameters (mm): 3,0 / 3,5 / 4,0 / 4,5 / 5,0 / 6,0	
	bright zinc plated stainless steel A2	Raised countersunk head full threaded PZD, lengths (mm): 12 to 60 diameters (mm): 3,0 / 3,5 / 4,0 / 4,5 / 5,0 HD, lengths (mm): 12 to 60 diameters (mm): 3,0 / 3,5 / 4,0 / 4,5 / 5,0	
	bright zinc plated stainless steel A2	Flange head full/part threaded T-Drive, lengths (mm): 40 to 500 diameters (mm): 6,0 / 8,0 / 10,0	
	bright zinc plated	Flange head XL part threaded T-Drive, lengths (mm): 160 to 400 diameter (mm): 8,0	
	bright zinc plated	Combihexagon head full/part threaded hexagon head + T-Drive, lengths (mm): 50 to 400 diameters (mm): 8,0 / 10,0	
	bright zinc plated	Cylindric head full threaded T-Drive, lengths (mm): 120 to 380 diameters (mm): 6,0 / 8,0 / 10,0	

	bright zinc plated
	yellow zinc plated
	stainless steel A2
	stainless steel A4
	HP-coated



ClicFix quick change tool holder
magnetic
anodized aluminium

Please contact your HECO specialist dealer for the exact delivery dates.

	bright zinc plated	Wood panel screw, countersunk head with milling grooves, full threaded HD, lengths (mm): 50 to 80 diameter (mm): 4,5	
	bright zinc plated stainless steel A2	Floorboard screw, raised countersunk head with milling ribs, full threaded T-Drive, lengths (mm): 40 to 80 diameters (mm): 3,5 / 4,0 / 4,5	
	bright zinc plated yellow zinc plated stainless steel A2	Glazing bead screw, countersunk head with milling ribs, part threaded T-Drive, lengths (mm): 30 to 60 diameter (mm): 3,5	
	stainless steel A2	Cladding screw, raised countersunk head full threaded HD, lengths (mm): 40 to 80 diameters (mm): 4,5 / 5,0	
	bright zinc plated stainless steel A2	Fitting screw, countersunk head full threaded HD, length (mm): 40 diameter (mm): 4,5	
	bright zinc plated	Back wall screw, flange head full threaded PZD, lengths (mm): 20 to 60 diameter (mm): 3,5 T-Drive, lengths (mm): 20 bis 60 diameter (mm): 3,5	
	stainless steel A2 stainless steel A4	Decking screw, countersunk head with milling ribs, part threaded HD, lengths (mm): 40 to 80 diameter (mm): 5,0	
	stainless steel A2 stainless steel A4	Decking screw, raised countersunk head secondary thread HD, lengths (mm): 40 to 80 diameter (mm): 5,0	
	HP-coated	Post screw, flange head full threaded T-Drive, lengths (mm): 40 to 60 diameters (mm): 6,0 / 8,0	
	bright zinc plated	Connector screw, flange head full threaded T-Drive, lengths (mm): 120 bis 160 diameter (mm): 10,0	
	bright zinc plated	Connector screw, countersunk head with milling grooves, full threaded HD, lengths (mm): 60 to 180 diameter (mm): 8,0 / 10,0	
	bright zinc plated	HECO-TOPIX®-plus Therm, countersunk head with milling grooves secondary thread HD, lengths (mm): 160 to 600 diameters (mm): 8,0 / 10,0	
	bright zinc plated	HECO-TOPIX®-plus CombiConnect, cylindric head secondary thread T-Drive, lengths (mm): 100 to 400 diameters (mm): 6,5 / 8,5	
	stainless steel A2	HECO-TOPIX®-plus-T Solar, flange head secondary thread T-Drive, lengths (mm): 240 to 360 diameter (mm): 8,0	

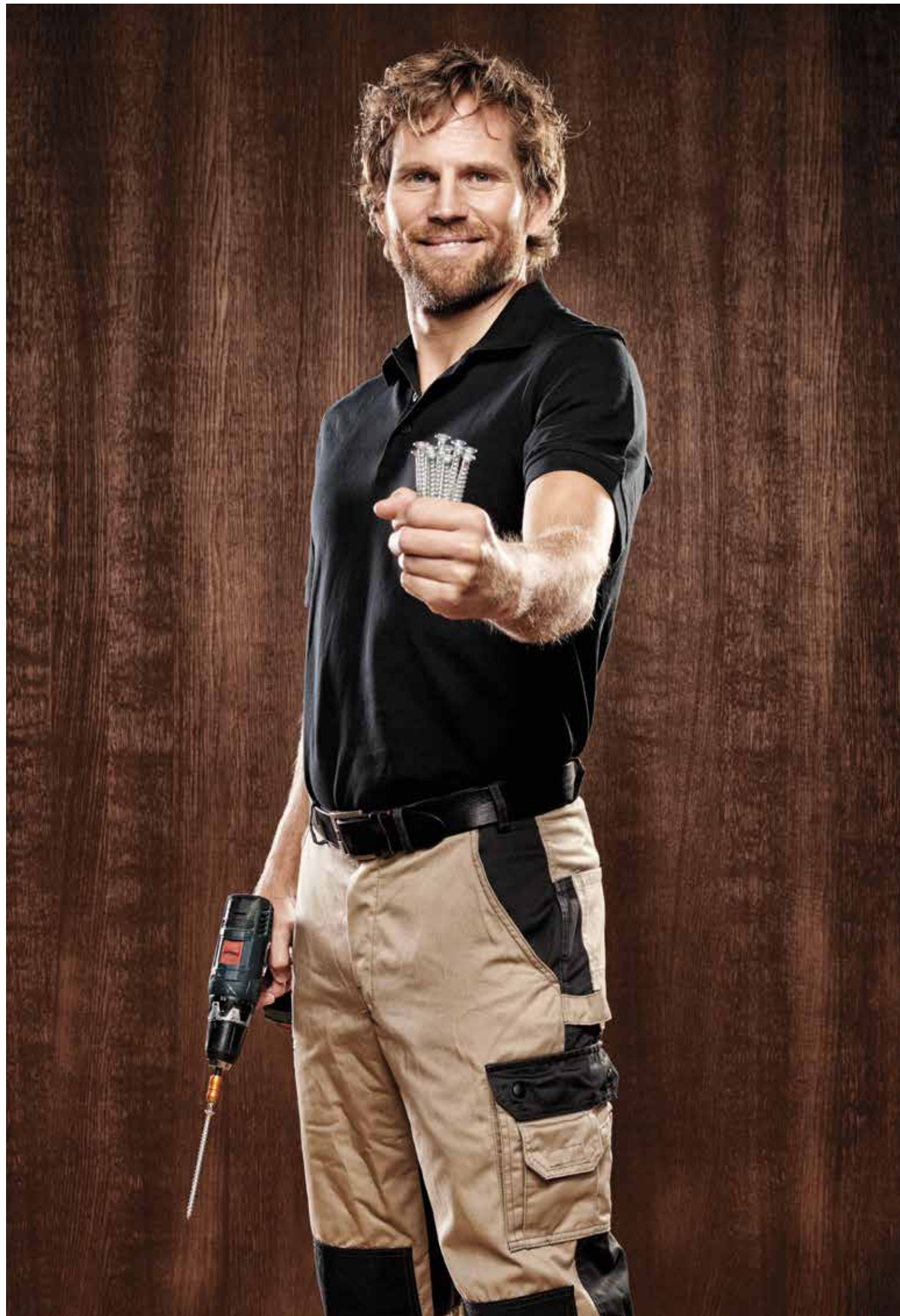

**HECO-TOPIX®-plus:
The one for all.**

Whether a carpenter, a joiner, a kitchen installer or a kitchen fitter: HECO-TOPIX®-plus is the right screw type for anyone who works with wood. HECO-TOPIX®-plus ensures optimal application performance for all timber applications and in all working situations. In short: HECO-TOPIX®-plus makes you better!

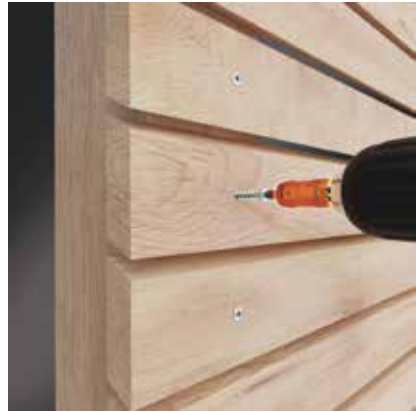

Façade assembly



Carcass assembly



Floorboard assembly

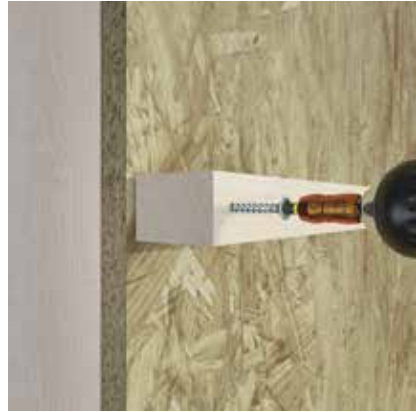

Mounting of installation level



On-rafter insulation

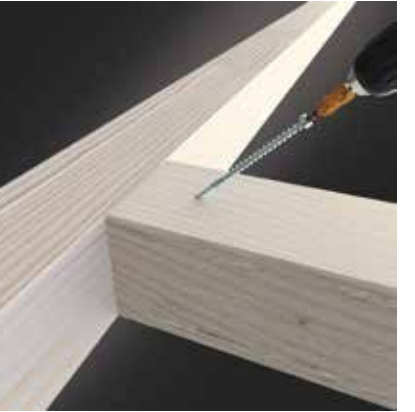

Connection of main and auxiliary beams



Rafter fastening



OSB panelling



Fastening of metal fittings